

Instructions for MAS-Sequencer (3 or 4 aspect com negative)

The MAS-Sequencer operates a signal in the following way:

The signal is normally at green. As a train passes the signal it will reach the MAS Sequencer which detects the train by its built in infra detection, Detecting a train causes the signal to change to red. Once the train is clear of the MAS-Sequencer s detector a timing sequence begins. This gives 3 equal timing intervals. The signal stays at red for the first interval, the signal changes to yellow for the second interval and for the third interval the signal changes to double yellow. At the end of which the signal changes to green. If another train arrives during this sequence then the signal will change to red and the sequence restarts.

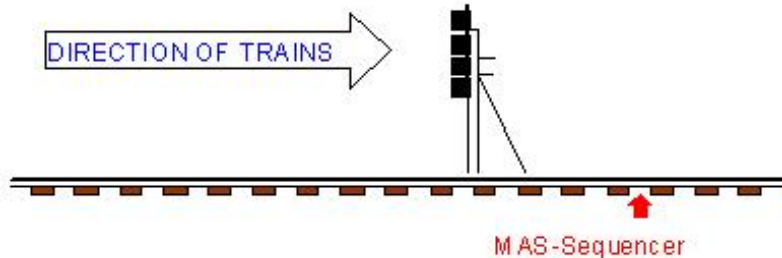

The MAS-Sequencer can be used on its own to control a single signal. If more than one signal is on the same line the extra signals can be operated by IRDASC-4 units. A connection from the MAS-Sequencer s "send" terminal to the following IRDASC-4s "receive" terminal tells the IRDASC-4 which aspect the MAS-

Sequencer is at. For example if the MAS-Sequencer is at yellow then the IRDASC-4 will set its signal to double yellow. Versions of the IRDASC-4 are also available for 2 and 3 aspect signals.

Position and fitting of MAS-Sequencer

Each MAS-Sequencer is positioned past the signal it controls. This position is important because the signal changes to red when the front of the train is detected. The unit is screwed to the underside of the baseboard with the infra red emitter and detector located in a hole between the sleepers.

It is easiest to install the units after the track is laid. Drill a small pilot hole between the sleepers. Fit an 8mm drill bit marked with tape for slightly less than the base board thickness. Drill from underneath the baseboard following the pilot hole. Cut or file the small amount of baseboard material left between the sleepers. Install the unit, and then fill the remainder of the hole with modelling material. Blue tack will hold the units in place temporarily.

When fitted to Z or N gauge track the gap between sleepers will be less than the diameter of the infra red detector and emitter. However, the modules work well provided they are adjusted to fit close to the sleepers. This positioning prevents reflections off the sleepers causing detection.

The modules will also operate on their side placed alongside the track. For thick baseboards and restricted space we can supply units with the emitter and detector fixed to wires up to 18 inches long.

Wiring

Power: The unit may be powered from either AC or DC a supply of 12 to 16volts. Connect the positive to all + terminals. Connect the negative to all 0V terminals. Check the LED on the MAS-Sequencer board only lights when rolling stock is over the detectors.

Signals: This unit operates a 3 or 4 aspect LED signal with common negative wiring. There are versions of the MAS Sequencer for signals with common positive wiring.

C=common

R=red

Y=yellow

DY=double yellow (extra yellow for 4 aspect signal)

G=green

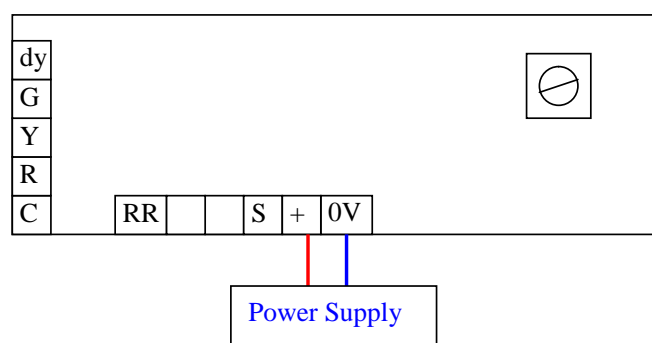

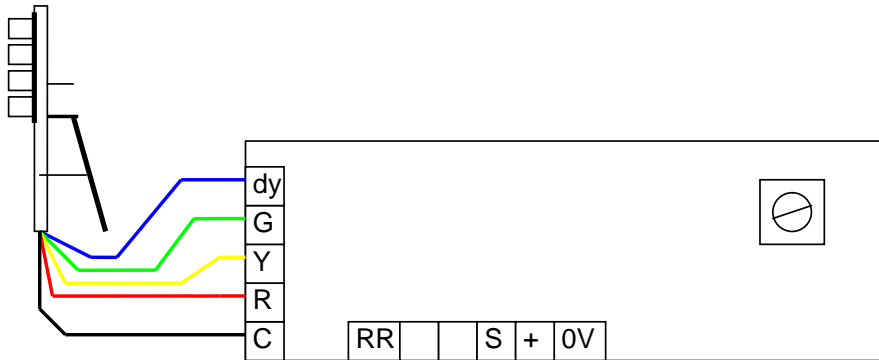

The diagram shows a 4 aspect common negative signal (all the short legs, cathodes, of the LEDs connect to the C Terminal).

Resistors to limit the current through the LEDs are built into the board. If resistors are supplied fitted to the signal it may be necessary to remove these

if the signal is not bright enough.

Timing of sequence: This is adjusted by rotating the "pot" on the board with a screwdriver. Turn anti-clockwise for longer times.

Interconnections between units: Two wires are used to send information between units. Send "S" is wired back to receive "R" of the IRDASC controlling the previous signal. This wire sends back information about the aspect that the next signal is set at. See page 3 for wiring details.

RR terminal: Use of this terminal is optional. Its purpose is to set the signal to red. It may be required to set the signal to red for signals at stations, for interlocking to points and junctions or when a train is running in the opposite direction to the signals. "RR" is activated by connecting to 0V (negative) and sets the signal to red. This connection may be made with a switch or with the direction detector. One switch or direction detector may be connected to a line of RR terminals. The diagram shows a switch arranged to connect "0V" to the "RR" terminal.

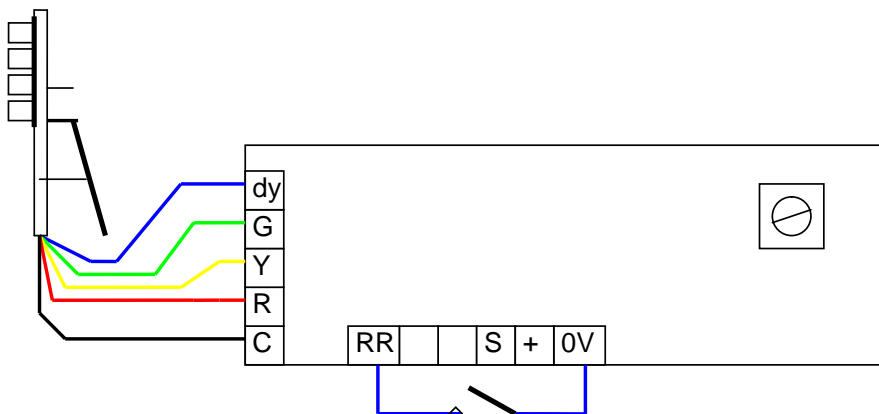

HEATHCOTE ELECTRONICS, 1 HAYDOCK CLOSE, CHEADLE, STAFFS, ST10 1UE
 TEL 01538 756800
 email cah@heathcote-electronics.co.uk
 web site www.heathcote-electronics.co.uk